

Custom Installation Series

CCM™ 50, CCM™ 65, CCM™ 80 Owner's manual

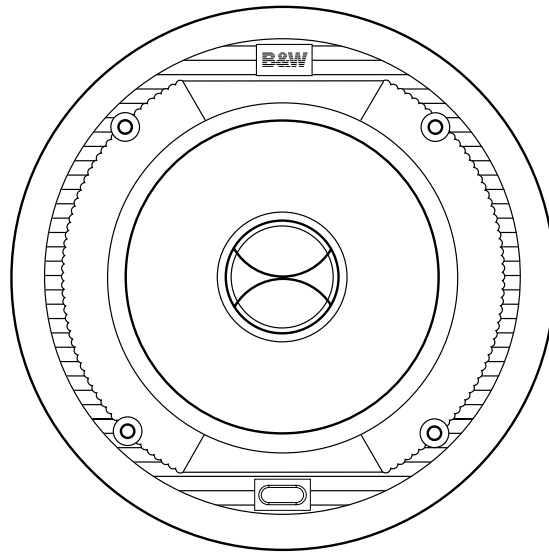

L I S T E N A N D Y O U ' L L S E E

Figure 1

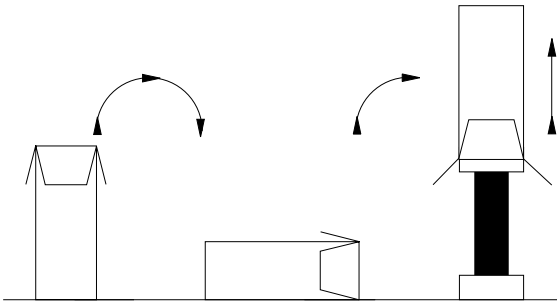
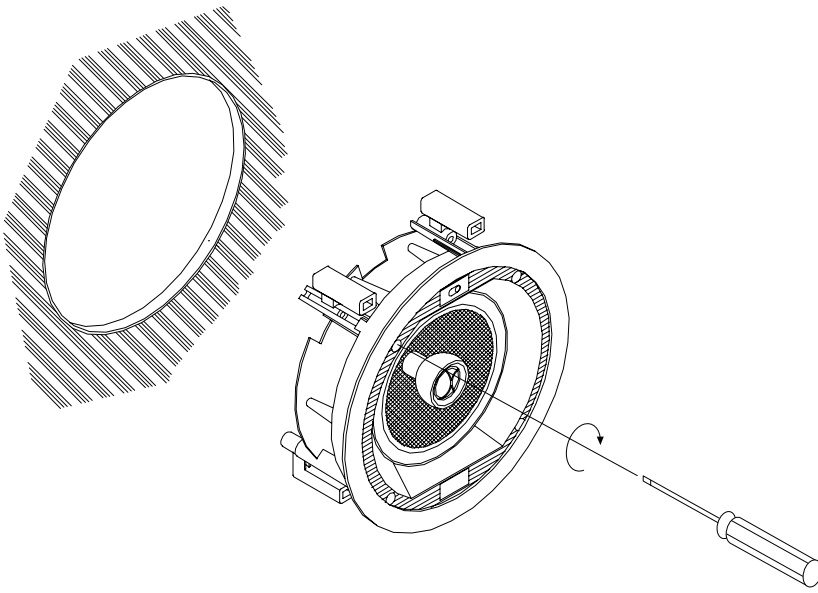

Figure 2



**Owner's manual
CCM™50, CCM™65, CCM™80**

English	1
Français	2
Deutsch	3
Español	4
Português	6
Italiano	7
Nederlands	8
Ελληνικά	9
Русский	10

INTRODUCTION

Thank you for purchasing B&W Custom Ceiling Mount (CCM™) speakers.

Since its foundation in 1966, the continuing philosophy of B&W has been the quest for perfect sound reproduction. Inspired by the company's founder, the late John Bowers, this quest has entailed not only high investment in audio technology and innovation but also an abiding appreciation of music to ensure that the technology is put to maximum effect.

It is also our policy to make sure the advanced features pioneered on one product are incorporated into others we manufacture. The CCM™ range incorporates woven Kevlar® cone mid/bass drive units for lowest coloration and maximum definition.

However, no matter how good the speakers themselves, they must work well into the listening room and time spent on planning the installation will reap the reward of many hours listening pleasure. Please read through this manual fully. It will help you optimise the performance of the system.

B&W distribute to over 50 countries worldwide and maintain a network of dedicated distributors who will be able to help should you have any problems your dealer cannot resolve.

UNPACKING

(figure 1)

- Fold the top carton flaps right back and invert the carton and contents.
- Lift the carton clear of the contents.
- Remove the inner packing from the product.

Check the contents:

- 2x Baffle with drive units, crossover
- 2x Frame with swing out dogs
- 2x Loudspeaker grille
- 1x Alignment template
- 2x Paint mask

We suggest you retain the packaging for future use. Remove the grilles from the wall frames and, to avoid damage, keep them in their plastic bags (and preferably in the carton) away from the work area until you are ready to fit them.

POSITIONING – NEW CONSTRUCTION VERSUS RETROFIT

Check that there is no conflict with other in-wall installations (pipe work, air conditioning, power-cabling etc.). In existing construction, use a stud-finding tool to map the wall construction accurately and a pipe detector to scan the proposed installation position. Avoid installing the speakers in the same cavity of the wall as flimsy ducting, which may be induced to rattle. The speakers are designed to operate satisfactorily in a wide range of cavity volumes, ideally above 15 litres (0.5 cu ft).

The speakers are balanced for half-space mounting (i.e. flush in a ceiling or soffit). Placement near a wall/ceiling junction or in a corner is to be avoided as it may give rise to too much bass and a boomy quality to the sound. If possible, keep the speakers more than 0.5m (20in) from the ceiling edges.

The following sections give guidance on optimum positioning, but this may be modified in line with domestic constraints.

Normal Ceiling Applications

For distributed sound, mount the loudspeakers in the ceiling. The spacing will depend on the height of the ceiling and the level of sound required. More speakers played at a lower level will give better clarity.

Home Theatre Surround Speaker Applications

The sound from surround speakers should be as diffuse as possible. This ensures that the frontal audio image is not distorted by changes of listener position or head movements. The speakers should generally be placed behind and 0.6m (2ft) or more above ear height. Ceiling mounting often gives good results in this application. The orientation is less important in this application than in other cases.

WARNING: The CCM™ speakers produce a static magnetic field that extends outside the cabinet boundary. As such they should not be placed within 0.5m (20in) of equipment that may be affected by such a field, e.g. Cathode Ray Tubes in TVs and Personal Computers.

DAMPING THE WALL CAVITY

In addition, loosely fill the whole section of the ceiling cavity with wadding. Fibreglass and mineral wool matting supplied for heat insulation are suitable, but not closed cell foam or expanded polystyrene. Check that there is no debris that may fall into the speaker (especially in ceiling mount situations).

IMPORTANT: YOU SHOULD CHECK THAT THE MATERIALS YOU USE MEET THE LOCAL FIRE AND BUILDING REGULATIONS.

FITTING THE WALL FRAME

New Construction

Fit the separately available pre-mount kit – (PMKc™50 for CCM™50, PMKc™65 for CCM™65, PMKc™80 for CCM™80) to the studding before the drywall panels are fitted, following the instructions supplied with the kit. The drywall panels should be fitted up to the pre-mount frame and plastered over.

Existing Construction

Push out the slots in the template provided. Position the template on the ceiling as required. Mark along the inside edges of the slots and cut out the aperture neatly.

All Methods

(figure 2)

Position the frame in the ceiling and screw in the 4 screws visible from the front of the frame. These screws swing out clamping dogs that locate behind the drywall. Ensure that they have located properly and tighten the screws. A certain amount of flexing of the frame is allowed to take up unevenness in the mounting surface, but do not over tighten the screws as excessive distortion of the frame may occur.

CUSTOMISING

The frame has a paintable white semi-matte finish, ready if necessary to be re-finished to match your own decor. Fit the paint mask before re-finishing. Do not re-finish the drive units or baffle area behind the grille. Avoid touching the drive units, as damage may result.

CONNECTIONS

All connections should be made with the equipment switched off.

The terminals accept bare wires. Connect the red (+ve) terminal to the positive terminal of the amplifier and the black (-ve) to the negative. Failure to observe correct polarity will result in ill-defined panning of sounds and strange phase effects.

When choosing cable, keep the total electrical impedance (out and back) below the maximum recommended in the specification. Ask your dealer for advice, as the optimum cable will depend on the length required. Cut off excess length and tie down loose cable to prevent rattles.

HF Controls

The switch on the front baffle (on the rear for the CCM™50) provides a boost or cut in the speaker's high-frequency output. Use it to adjust the high-frequency level to compensate for severely off axis positioned speakers or heavy wall coverings (Boost) or speakers positioned in highly sound reflective rooms (Cut). In addition the tweeter assembly on the CCM™65 and CCM™80 can be swivelled to adjust the off axis treble response by "aiming" the tweeter towards the listening area.

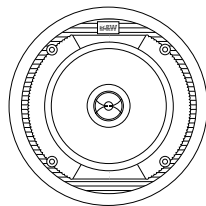
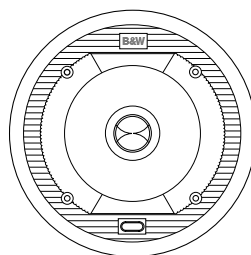
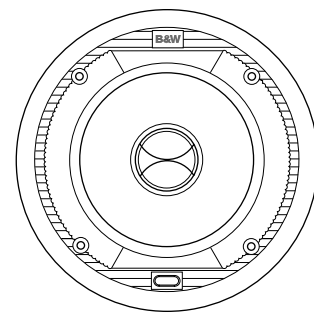
**CCM™50****CCM™65****CCM™80**

Drive units	1x 125mm (5in) Kevlar® mid/bass 1x 25mm (1in) high-frequency	1x 165mm (6½ in) Kevlar® mid/bass 1x 25mm (1in) metal dome high-frequency	1x 200mm (8in) Kevlar® mid/bass 1x 25mm (1in) metal dome high-frequency
Frequency response	55Hz – 20kHz ±3dB	50Hz – 20kHz ±3dB	40Hz – 20kHz ±3dB
Sensitivity	88dB spl (2.83V, 1m)	89dB spl (2.83V, 1m)	90dB spl (2.83V, 1m)
Nominal impedance	8Ω	8Ω	8Ω
Crossover frequency	3.5kHz	3.5kHz	3.5kHz
Recommended amplifier power	20W – 100W continuous into 8Ω on unclipped programme.	20W – 130W continuous into 8Ω on unclipped programme.	20W – 150W continuous into 8Ω on unclipped programme.
Protection	Auto-Reset Polyswitch	Auto-Reset Polyswitch	Auto-Reset Polyswitch
Frame size	Diameter: 201mm (7¾ in)	Diameter: 232mm (9¼ in)	Diameter: 280mm (11 in)
Cut-out size without pre mount frame	Diameter: 175mm (6 7/8 in)	Diameter: 206mm (8 1/8 in)	Diameter: 254mm (10 in)
Cut-out size with pre mount frame	Diameter: 182mm (7 1/8 in)	Diameter: 213mm (8 3/8 in)	Diameter: 261mm (10 1/4 in)
Min depth required	80mm (3 1/8 in) from ceiling surface	95mm (3 3/4 in) from ceiling surface	100mm (4 in) from ceiling surface
Finishes	Semi-matt white suitable for customising or pre-painting	Semi-matt white suitable for customising or pre-painting	Semi-matt white suitable for customising or pre-painting
Pre-mount frame (optional)	PMKc™50	PMKc™65	PMKc™80



L I S T E N A N D Y O U ' L L S E E

Kevlar is a registered trademark of DuPont.

B&W Loudspeakers Ltd. reserves the right to amend details of the specification without notice in line with technical developments.
Copyright © B&W Loudspeakers Ltd. Printed in England.

B&W Loudspeakers Ltd, Meadow Road, Worthing, BN11 2RX Tel: +44 (0) 1903 524801 Fax: +44 (0) 1903 524725
B&W Loudspeakers of America, 54 Concord Street, North Reading, MA 01864-2699, USA Tel: (1978) 664 2870 Fax: (1978) 664 4109
<http://www.bwspeakers.com>